

INSTALLATION OF FRONT MOUNTING KIT 2008 FORD F-250/350 4x4

SAFETY PRECAUTIONS

If any installation problems are encountered, please call G&B Specialties for technical assistance before continuing with the installation process.



- Failure to heed to any of the following warnings could result in severe bodily injury and/or equipment damage.
- Read and understand this manual completely before attempting installation of the equipment.
- Installation instructions provided below only address the Rafna Industries railgear equipment. Applicable railway company procedures and policies must be adhered to.
- Before performing any work under the vehicle or railgear, ensure the engine is turned off and the parking brake is set.
- Do not start the vehicle with the power steering hoses disconnected. Reconnect all hoses, and secure the power steering cooler if the vehicle is started.
- Ensure all removed components are given to the vehicle owner after the installation of the railgear. These components must be re-installed if the railgear is removed from the vehicle.
- Always disconnect the vehicle's battery when welding on the vehicle or railgear in order to protect the vehicle's electrical system.

INSTALLATION OF FRONT MOUNTING KIT

The following procedure details the installation of the front mounting kit. The hardware required for this installation is listed in table 1.

Table 1: Front Mounting Kit Installation Parts

Part Number	Description	Qty
R-11100D-A	Mounting Bracket - Drivers Side	1
R-11100P-A	Mounting Bracket - Passengers Side	1
R-12009-C	Frame Extension - Drivers Side	2
R-11111	Bumper Spacer - 5"	4
R-11112	Tow Hook Spacer, 1/2"	2
R-11113	Tow Hook Spacer, 1"	2
R-2960A	Railgear Mounting Shim - 1"	2
R-2631	Railgear Mounting Shim - 2"	2
R-2960	Railgear Mounting Shim - 1/2"	4
R-990KIT-209	3/4" UNC GR.8 Bolt x 3.50" Lg.	4
	3/4" UNC GR.8 Bolt x 4.50" Lg.	4
	3/4" UNC GR.8 Bolt x 5.50" Lg.	4
	3/4" Flat Washer, GR.8 - Type-A	8
	3/4" UNC GR.8 Nylon Insert Lock Nut	4
	5/8" UNC GR.8 Bolt x 6.00" Lg.	8
	5/8" Flat Washer, GR.8 - Type-A	16
	5/8" UNC GR.8 Nylon Insert Lock Nut	8
	1/2" UNC GR.8 Bolt X 2.50" Lg.	6
	1/2" UNC GR.8 Bolt X 3.00" Lg.	6
	1/2" UNC GR.8 Bolt X 3.50" Lg.	6
	1/2" UNC GR.8 Bolt X 1.50" Lg.	8
	1/2" Flat Washer, GR.8 - Type-A	22
	1/2" UNC GR.8 Nylon Insert Lock Nut	8
	R-990KIT-410	7/16" UNC GR.8 Bolt X 1.50" Lg.
7/16" UNC GR.8 Bolt X 2.50" Lg.		6
7/16" UNC GR.8 Bolt X 3.00" Lg.		6
7/16" UNC GR.8 Bolt X 3.50" Lg.		6
7/16" UNC GR.8 Nylon Insert Lock Nut		8
7/16" Flat Washer, GR.8 - Type-A		16
R-051	Side Wand Set	1

Frame Modification (Figures 1, 1A & 1B)

1. Remove the front bumper and front tow hooks if so equipped. Remove the coolant line retaining clips from both the inside driver and passenger frame rail. The coolant line retaining clips will need to be relocated in an appropriate place by the installer.

- a.) Remove Front Compatibility brackets from front frame horns.
Applies to 2010 Model Year and newer trucks.

2. Retain the front bumper and tow hooks for re-installation.
3. On the in-board side of the driver's side frame rail, drill out the first two existing holes to 11/16" diameter. Drill both holes thru to the out-board side of the frame and thru the out-board frame rail.
4. On the in-board side of the passenger's side frame rail, drill out the first two existing holes to 11/16" diameter. Drill the first two holes thru to the out-board side of the frame and thru the out-board frame rail.
5. Drill the existing three holes in the top of the drivers frame rail to 9/16" diameter.

If the frame extensions supplied with this kit do not have the nuts welded to the inside then it will not be necessary to complete step #5

Bracket Assembly - Drivers Side (Figure 2 & 2A)

1. Insert frame extension into frame and align with first two the holes in the frame and with the holes in the top of the frame. Attach the frame extension to the frame using a 1/2" X 1-1/2" bolt and flat washer inserted thru one of the holes drilled in the top of the truck frame and into the frame extension - tighten but do not torque at this time (this is to hold the frame extension in place for mounting the railgear bracket). There are 1/2" nuts welded to the inside of the frame extension. Make sure that the top of the frame extension is tight up against the inside top surface of the truck frame.

- 1a. **Use only If the frame extension supplied with this truck does not have the nuts welded to the inside... otherwise continue with step #2:**

Insert frame extension into frame and align with first two the holes in the frame and with the holes in the top of the frame. Attach the frame extension to the frame using a 7/16" X 1-1/2" bolt, flat washer and nut inserted thru one of the holes in the top of the truck frame and thru the frame extension - tighten but do not torque at this time (this is to hold the frame extension in place for mounting the railgear bracket). Make sure that the top of the frame extension is tight up against the inside top surface of the truck frame.

2. Assemble the railgear mounting bracket to truck frame and frame extension using 5/8" bolts, flat washers and nylon insert lock nuts. Make sure that the mounting bracket is tight up against the bottom of the frame and frame extension and the inside frame rail. Torque all 5/8" fasteners to 150 ft-lbs dry.
3. Repeat steps 1 thru 2 for passenger's side.
4. The supplied mounting shims are to be used as required when mounting the railgear to the front mounting brackets.

Front Bumper Bracket Mounting (frame extension *with* nuts) (Figure 3)

The OEM truck bumper can be re-installed on the truck using the OEM bumper/tow hook mounting brackets. It will be required to use bumper spacers as show when re-installing the truck bumper. It may also be necessary, but not required, to use the tow hook spacers to raise the OEM bumper for clearance of railgear components, depending on truck ride height. If using spacers, either the 1/2" or 1" spacers but do not use both. Using the tow hook spacers will also limit the amount of bumper trimming required.

1. The OEM bumper/tow hook mounting bracket will need modified for re-installation. The three threaded holes in the bracket will need to be drilled to 17/32" diameter.
2. Remove the 1/2" bolt that is holding the frame extension to the truck frame.
3. If not using spacers, place the OEM bumper mounting bracket on top of the truck frame, align holes and attach to frame/frame extension using 1/2" x 2-1/2" bolts and flat washers. There are 1/2" nuts welded to the inside of the frame extension
4. If using spacers, place either the 1/2" or 1" spacer on top of the frame (not both), place the OEM bumper mounting bracket on top of the spacer, align holes and attach to frame/frame extension using 1/2" bolts and flat washers. There are 1/2" nuts welded to the inside of the frame extension
5. Use the 1/2" x 3" long bolts and flat washers if using the 1/2" spacer or 1/2" x 3-1/2" bolts and flat washers if using the 1" spacer.
6. Torque all 1/2" fasteners to 100 ft-lbs dry.

Front Bumper Bracket Mounting (frame extension *without* nuts) (Figure 3A)

The OEM truck bumper can be re-installed on the truck using the OEM bumper/tow hook mounting brackets. It will be required to use bumper spacers as show when re-installing the truck bumper. It may also be necessary, but not required, to use the tow hook spacers to raise the OEM bumper for clearance of railgear components, depending on truck ride height. If using spacers, either the 1/2" or 1" spacers but do not use both. Using the tow hook spacers will also limit the amount of bumper trimming required.

1. The OEM bumper/tow hook mounting bracket will need modified for re-installation. The three threaded holes in the bracket will need to be drilled to 1/2" diameter.
2. Remove the 7/16" bolt that is holding the frame extension to the truck frame.

3. If not using spacers, place the OEM bumper mounting bracket on top of the truck frame, align holes and attach to frame/frame extension using 7/16" x 2-1/2" bolts and hardware.
4. If using spacers, place either the 1/2" or 1" spacer on top of the frame (not both), place the OEM bumper mounting bracket on top of the spacer, align holes and attach to frame/frame extension using 7/16" bolts and hardware.
5. Use the 7/16" x 3" long bolts if using the 1/2" spacer or 1/2" x 3-1/2" bolts if using the 1" spacer.
6. Torque all 7/16" fasteners to 65 ft-lbs dry.

Front Bumper Mounting (Figure 3)

1. Attach bumper spacers as shown using 1/2" x 1-1/2" bolts, flat washers and nylon insert lock nuts.
2. Attach OEM bumper to spacers as shown using 1/2" x 1-1/2" bolts, flat washers and nylon insert lock nuts.
3. Torque all 1/2" fasteners to 100 ft-lbs dry.

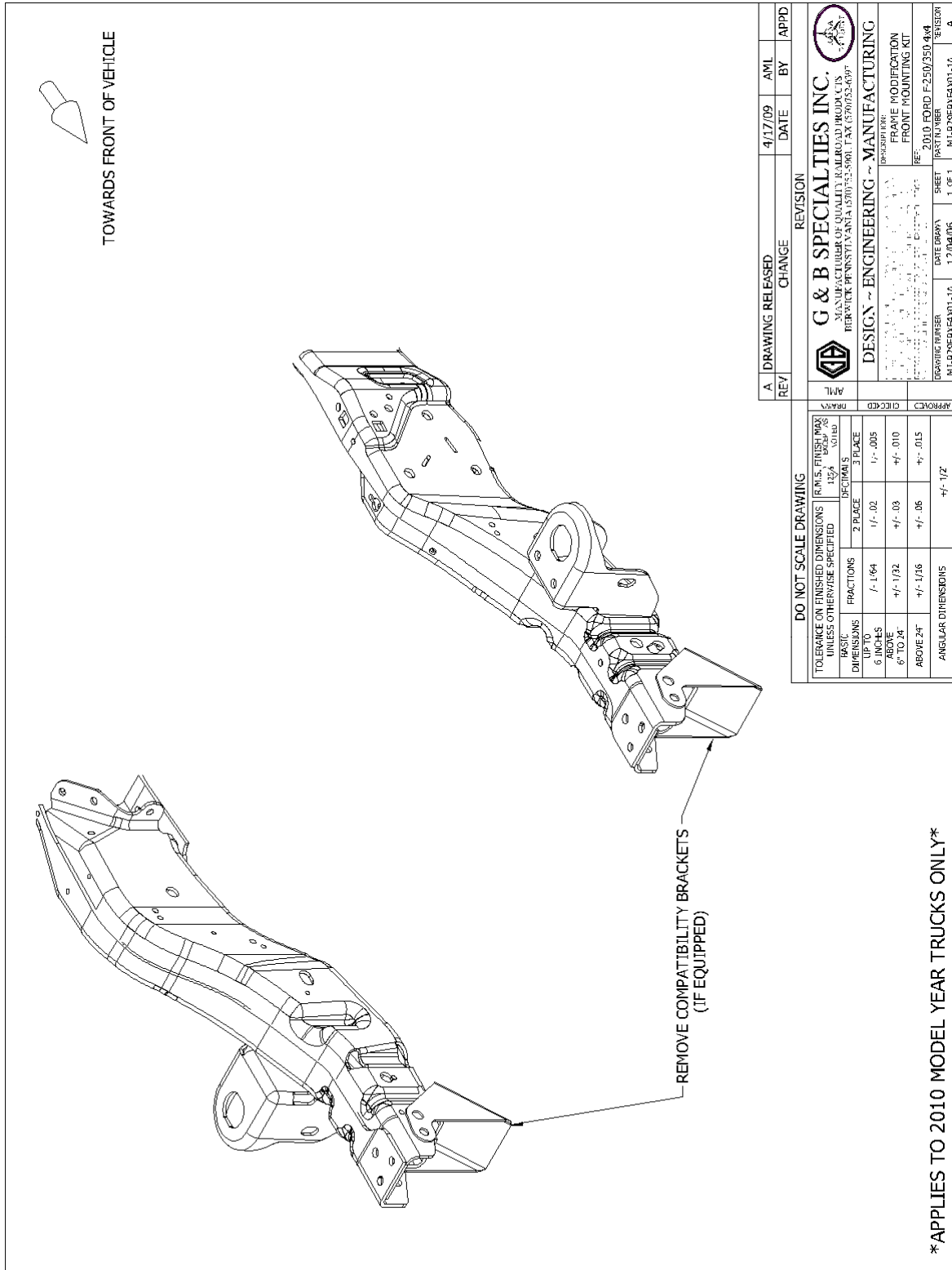

Figure 1

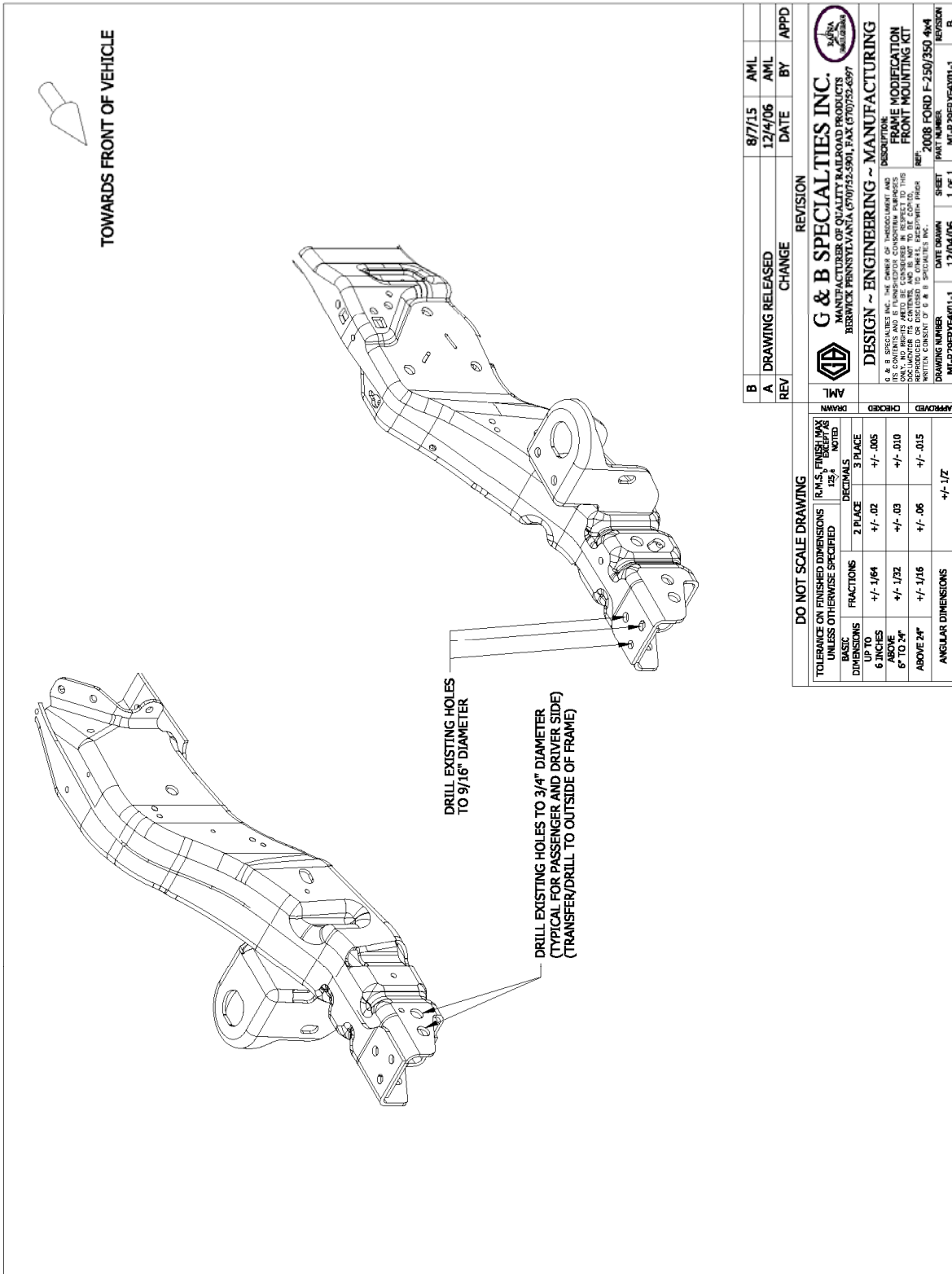

Figure 1A

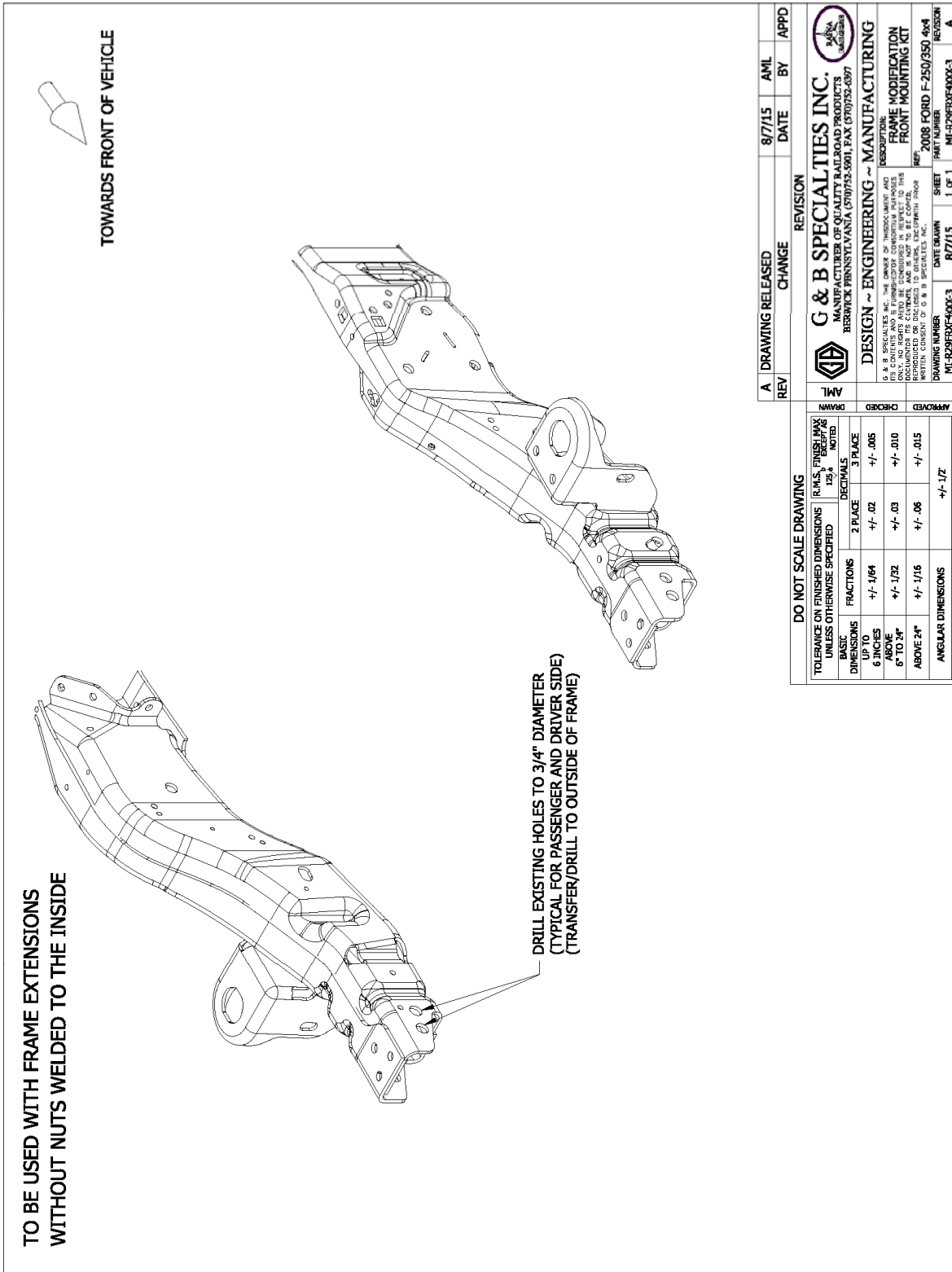

Figure 1B

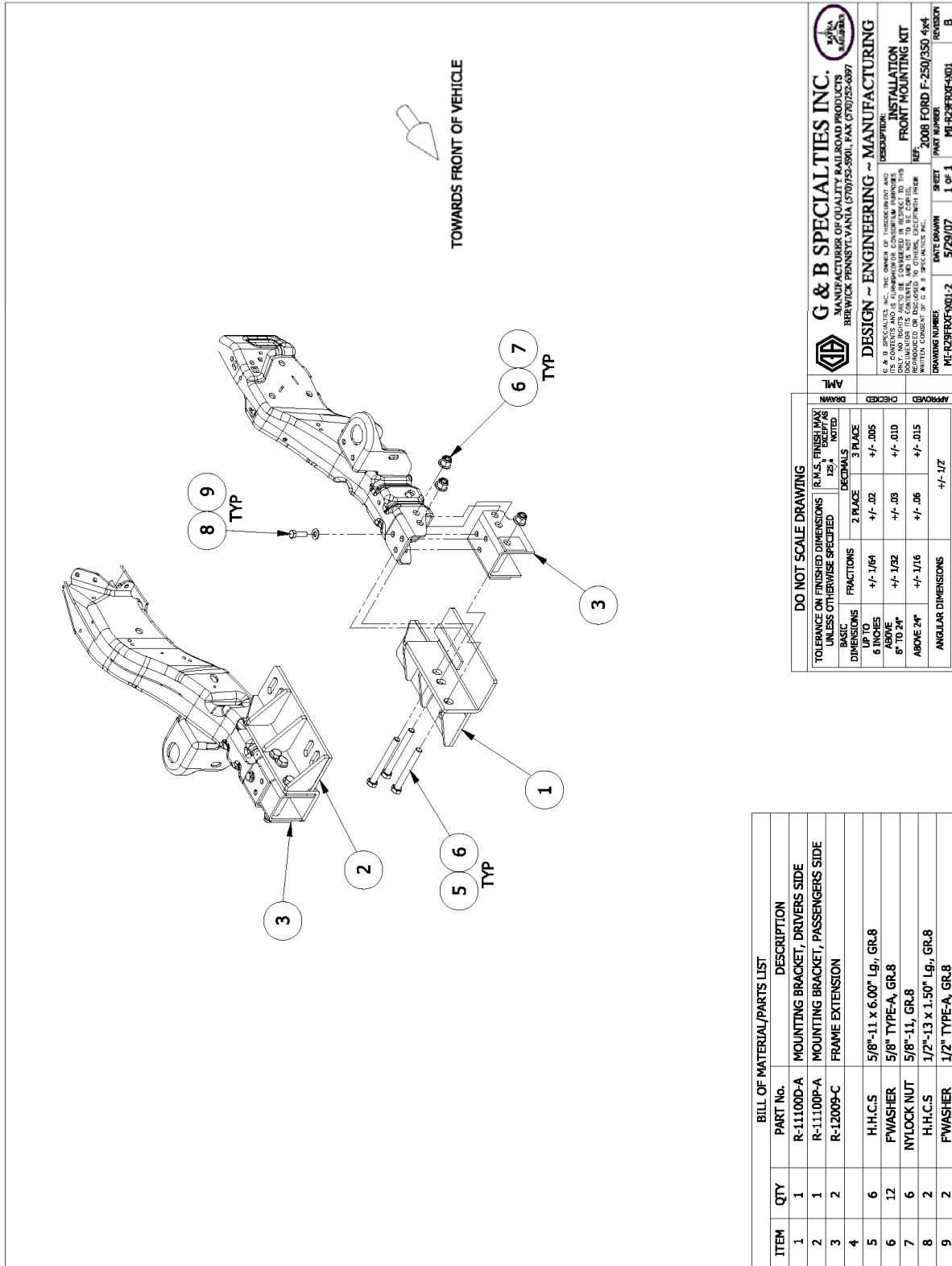

Figure 2

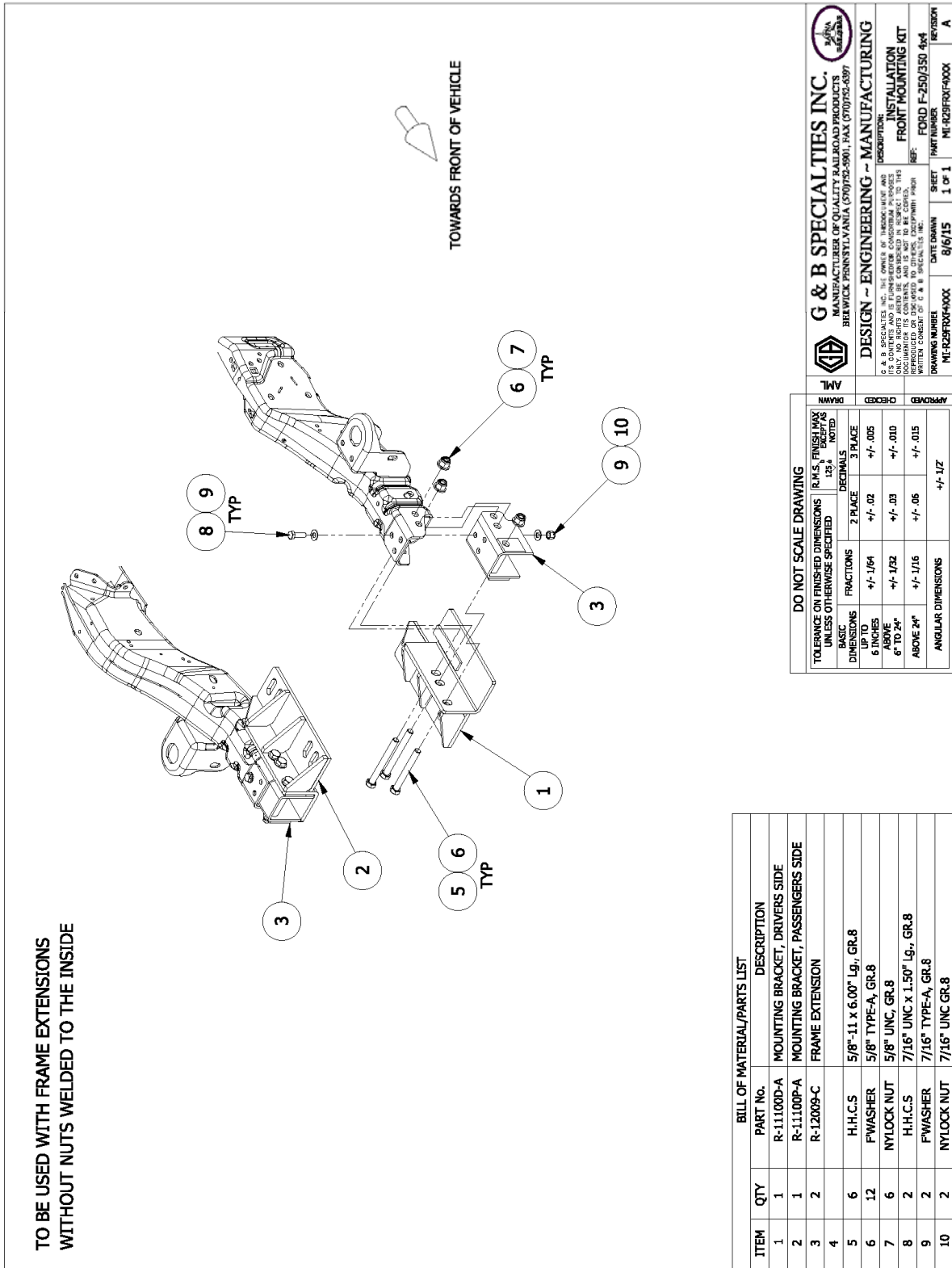

Figure 2A

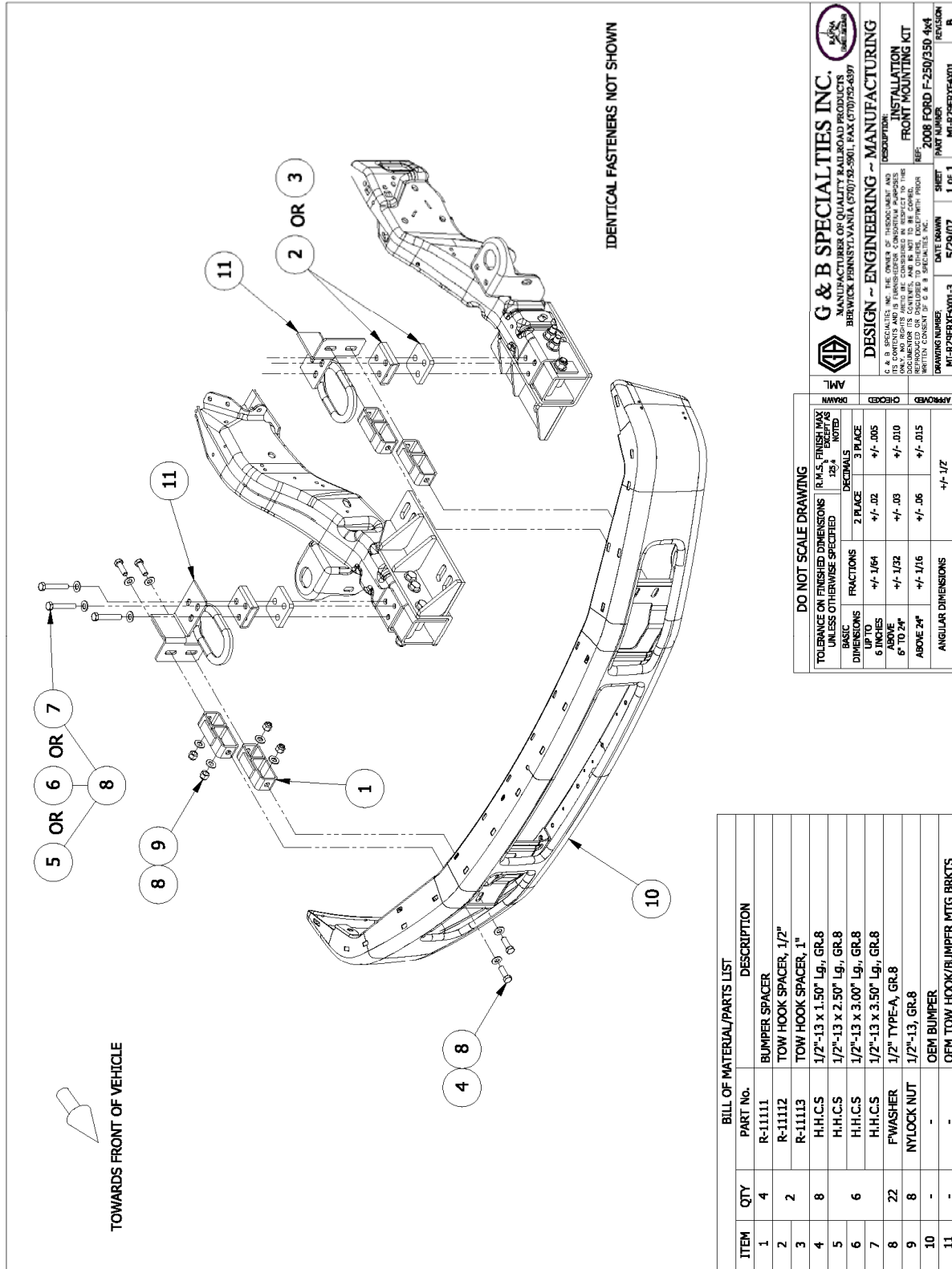

Figure 3

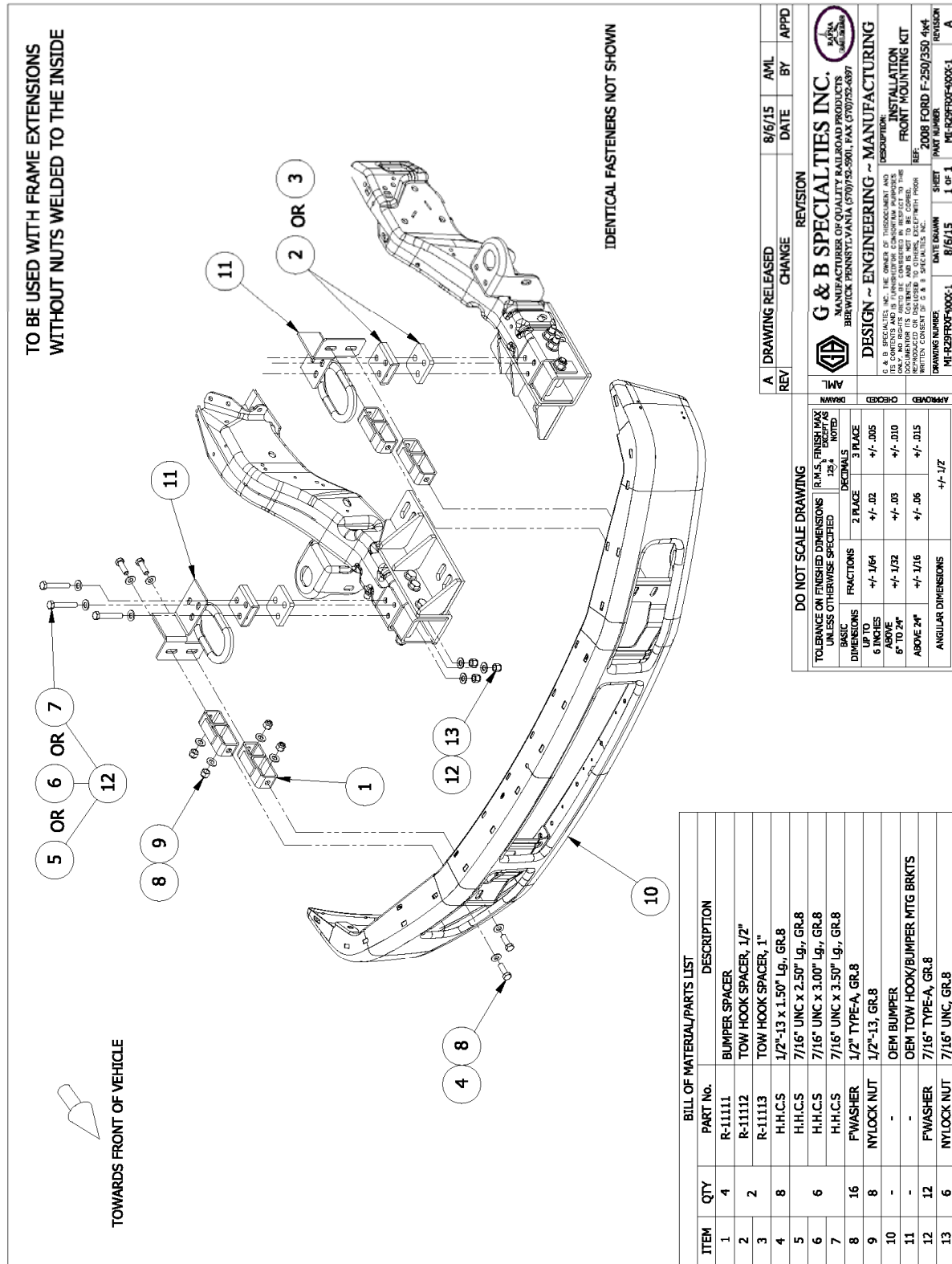

Figure 3A

OPERATION, SERVICE AND PARTS OF FRONT MOUNTING KIT 2008 FORD F-250/350 4X4

SAFETY PRECAUTIONS

If any operating, services or parts problems are encountered, please call G&B Specialties for technical assistance.



- Failure to heed to any of the following warnings could result in severe bodily injury and/or equipment damage.
- Read and understand this manual completely before attempting operation of the railgear equipped vehicle.
- Operating instructions provided below only address the Rafna Industries railgear equipment. Applicable railway company procedures and policies must be adhered to.
- Railway Company rules governing rail travel must be observed at all times.
- Before performing any work under the vehicle or railgear, ensure the engine is turned off and the parking brake is set.
- Never operate the vehicle if the Gross Vehicle Weight Rating (GVWR), Gross Axle Weight Rating Front or Rear (GAWR), or the wheel or tire load ratings are exceeded.

OPERATION OF FRONT MOUNTING KIT

With the front mounting kit installed on this vehicle, it may be operated as normal, however the front bumper is located further forward than standard. Side wands are located on the front bumper to aid in determining the length and width of the vehicle. Caution must be used when operating the vehicle.

Never operate the vehicle if the Gross Vehicle Weight Rating (GVWR), Gross Axle Weight Rating Front or Rear (GAWR), or the wheel or tire load ratings are exceeded.

SERVICE OF FRONT MOUNTING KIT

The front mounting kit must be serviced regularly to avoid damage to the equipment. Table 1 below provides the Recommended Service Schedule and Table 2 provides Standard Fastener Torque Values.

Table 1: Recommended Service Schedule

Service Required	Initial 62 miles (100 km) of road and/or rail use	Daily	Weekly	Monthly
Inspect front mounting kit fasteners (re-torque if required)		✓	✓	✓

Table 2: Standard Fastener Torque Values

Fastener Size	Fastener Torque Value (ft-lbs) Dry
1" UNC Gr. 8 Fasteners	250
3/4" UNC Gr. 8 Fasteners	175
5/8" UNC Gr. 8 Fasteners	150
1/2" UNC Gr. 8 Fasteners	100
7/16" UNC Gr. 8 Fasteners	65
3/8" UNC Gr. 8 Fasteners	40
1/4" UNC Gr. 8 Fasteners	12